

RANDCASTLE'S

Tubing & Wire Coating Lines

Introduction: This flexible line is used for research and development for both tubing and wire coating. Built with extruders between ¼ and 1¼ inches, our patented Surge Suppression system offers outstanding pressure stability. Studies have shown that pressure stability can be better than with a gear pump at a fraction of the cost. The small extruder size means short residence time for low output applications like catheters and coextrusion strippers.

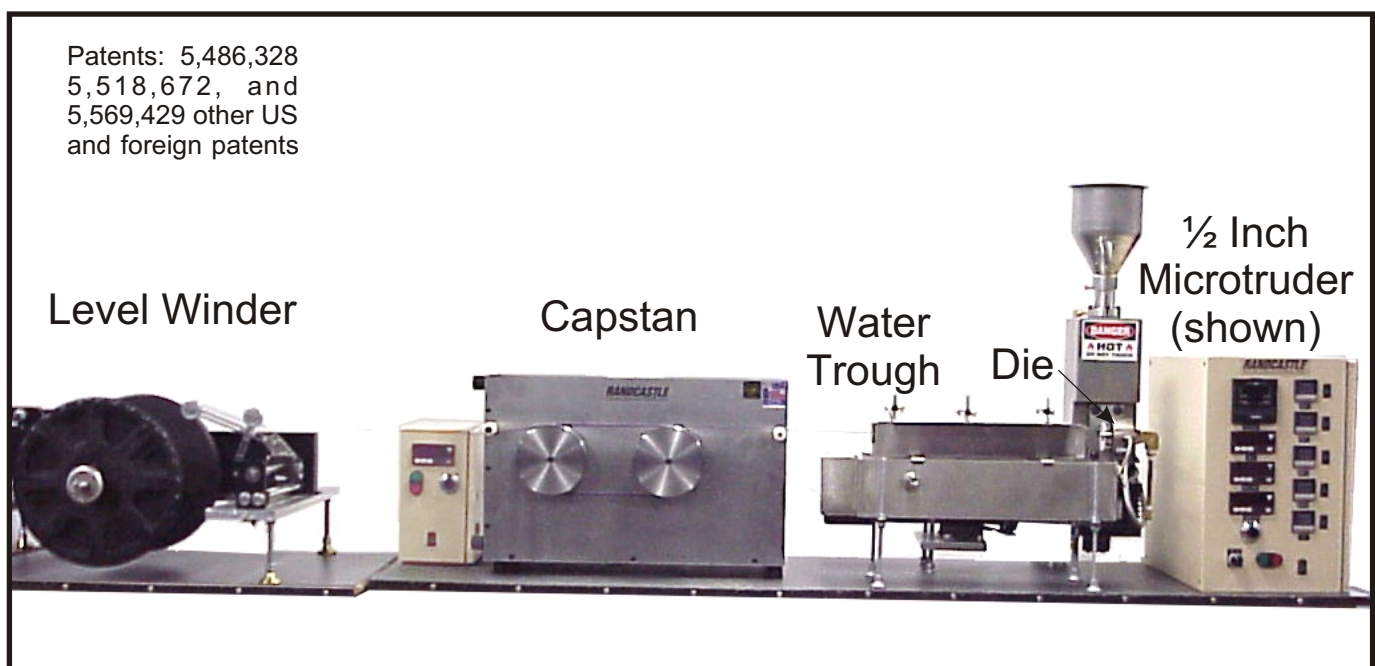

Dies: Dies can be fixed or adjustable center and supplied with heads for tubing, pressure coating, or jacketing.

Air Pressure Controller: For free extrusion applications, our air pressure control supplies adjustable air pressures from 0 to 15 inches of water.

Water Trough: Stainless steel double water trough is supplied with three guides for alignment. The upper trough slides easily for adjustment to the die. A water recirculation pump is included.

Capstan: The dual drum capstan has four grooves in each capstan wheel to give you all the surface area you need to pull without deformation of the product. The DC motor and control offer outstanding speed range and can be customized for your application.

Level Winder: The winder control has adjustable tension so it adjusts to the line speed automatically. The rate of traverse is adjustable independently of winder tension. Thus, both line speed and traverse rate adjust to speed of the capstan making it easy to operate. The winder uses off the shelf plastic cores and is equipped with quick locking collars to simplify operation.

RANDCASTLE'S *Capstan*



Multiple wrap capstan pulls small cross section extrudates such as wire, tubing, and filaments. Capstan can be used vertically, as shown, or horizontally by repositioning the inlet guide.

Randcastle Lines

Randcastle extrusion lines are available in a variety of sizes to meet your application needs. Typical lines are shown below including our latest developments: *Coextrusion blown film capable of up to 15 layers and our state of the art 50:1 L/D compounder..*

**World's
Most
Compact
Line!**

Six Extruder 11 Layer Line

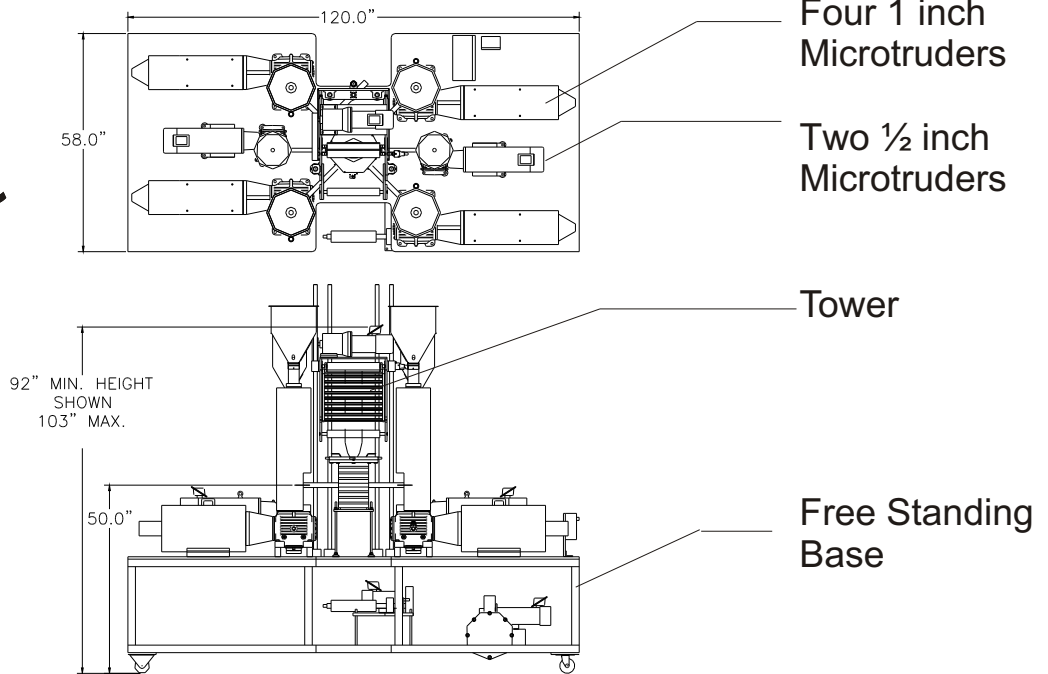

Additional Randcastle Lines

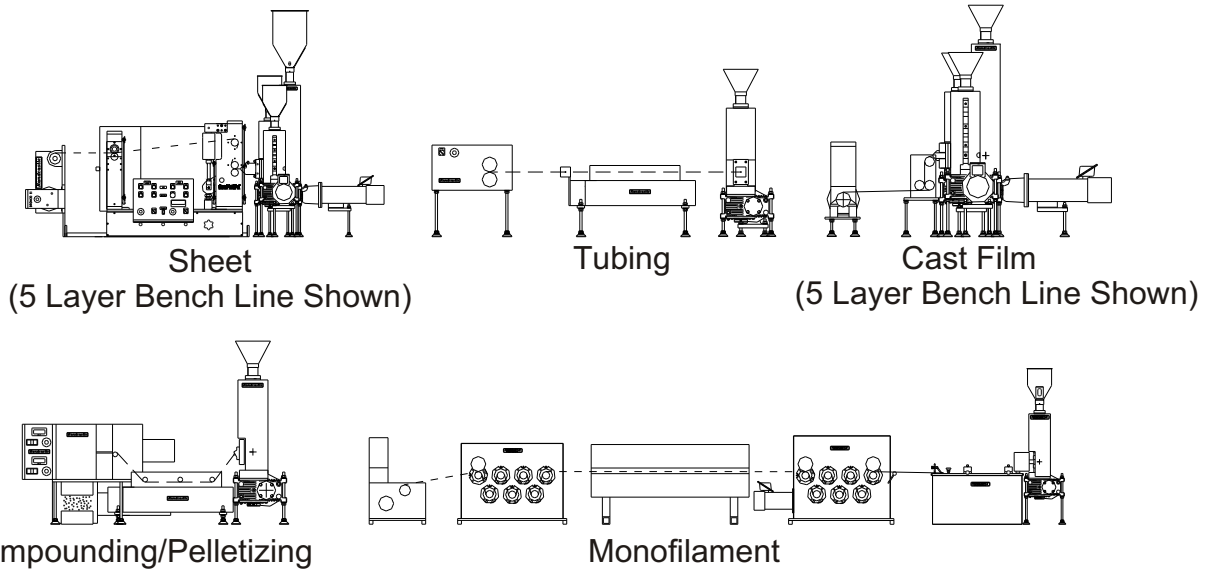

TubingWireBro2000NPE.CDR

For more information on Randcastle's line, contact:

Randcastle Extrusion Systems, Inc.
74 Sand Park Rd.
Cedar Grove, NJ 07009-1210 USA

Tele: 973-239-1150
Fax: 973-239-0830
email: kluker@mail.eclipse.net
Web Site: www.randcastle.com